

# Flo 22 Console 400 Wall 1 Door

exclusive to  
**plumbingworld**

## CABINET SPECIFICATION



### Product Features

Product Code	9805
Product Description	Flo 22 Console - 400 Wall
Cabinet Material*	Durashell®
Drawer Configuration	1 Door
Notes	Drawing depicts cabinet only

\*Both the cabinet front and sides are made of Durashell®, except for Baroque Woodgrain and Classic White Satin, which feature Durashell® fronts and matching Melamine sides (with Aqua Edge®).

### Cabinet Finishes Available



- Flo F2 Finish** 1. Classic White Satin,  
**Flo F3 Finish** 2. Black Satin, 3. Lana Grey Satin, 4. Slate Matte,  
 5. Pistachio Matte, 6. Villa Blue Matte, 7. Baroque Woodgrain

### Handle Colours Available



- Soul Handle** 1. Matte Black, 2. Brushed Brass, 3. Brushed Nickel, 4. Gunmetal,  
 5. Chrome, 6. Matte White, 7. Brushed Copper.

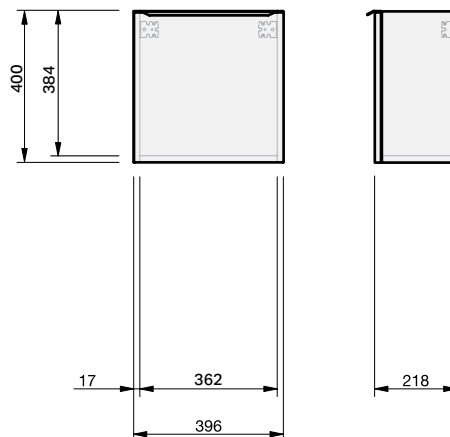
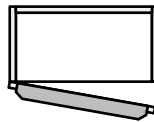

**IMPORTANT NOTE:** Throughout this guide, dimensions may vary by  $\pm 2$ mm. Please read the installation manual for detailed information on installing the product. St. Michel pursues a policy of continuing improvement in design and manufacturing of its products. The right is therefore reserved to vary specifications without notice.

**st.michel**  
BATHROOMWARE

phone (09) 837 4276 email [info@stmichel.co.nz](mailto:info@stmichel.co.nz) [stmichel.co.nz](http://stmichel.co.nz)

# Penelope 400

## BASIN SPECIFICATION



### Product Features

Product Code	2320
Type of basin	Console
Material of basin	Mineral Cast
Capacity of basin	1 litre
Overflow Configuration	Overflow supplied Overflow Rings supplied: chrome, white, black Max tap flow rate 9 litres / minute
Colour options	White Gloss

- Can not be wall hung.
- The basin must be sealed to the top with an acetic cured silicone sealant.
- Epoxy type sealants must not be used.
- The basin is reversible.

INDICATES TOP SURFACE -----

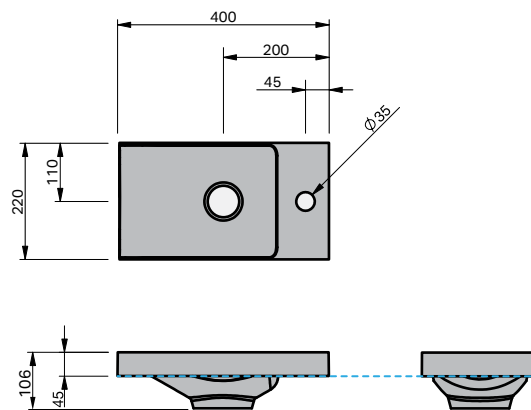

**IMPORTANT NOTE:** Throughout this guide, dimensions may vary by  $\pm 2$ mm. Please read the installation manual for detailed information on installing the product. St. Michel pursues a policy of continuing improvement in design and manufacturing of its products. The right is therefore reserved to vary specifications without notice.

st.michel  
BATHROOMWARE

phone (09) 837 4276 email [info@stmichel.co.nz](mailto:info@stmichel.co.nz) [stmichel.co.nz](http://stmichel.co.nz)